

Ranger Design

Commercial Van Equipment

Adding efficiency and function
to your commercial vehicles



Efficiency

Ranger Design has provided practical solutions for your vehicle since 1988. These years of experience and product development have resulted in outstanding equipment that does the job efficiently and is built to last.



1 Ladder Rack

Ranger racks make loading and unloading ladders an easy, one-person operation. Built of aluminum and stainless steel, they are strong, durable, and rustproof.



2 Partition

Ranger's contoured partitions provide a solid barrier between the cargo and the occupants of the van. Not only do they reduce sound, but they also provide a more comfortable environment for the driver.



3 Shelving

Designed to organize and store, Ranger shelves are contoured to maximize the floor space and storage capabilities of your vehicle. Dividers can be repositioned to best accommodate your payload.



4 Bin Shelving

Ranger bin shelves keep all your parts easily accessible, and in full view. Shelves are sloped back to avoid spillage of stock and include a complete outfit of durable bins.



5 Drawer Systems

Ranger drawer systems allow fast, easy access to your most-used tools. Drawers slide on durable guides or ball bearing rollers.



6 Accessories

Accessories complete your vehicle outfitting, making it safe and efficient. A full range of products will help to minimize clutter, better place the most useful items, and provide safety equipment as required.

Add efficiency and function



Benefits

Strong

Ranger products are built strong and durable. All Ranger components are constructed using heavy-gauge aluminum alloy 5052H32 and 6061T6 extrusions. Ranger products often outlast the vehicle they are in, and can be transferred to a newer van or truck.

Custom-fit

Ranger's product line is constantly evolving to ensure we have the precise product application required for your vehicle. Products are designed to fit with maximum efficiency. Proper fit translates into a better usage of the available work space.

Rustproof

Ranger has successfully eliminated all possibility of rust by building products exclusively of aluminum and stainless steel, which means a longer product life. As an additional bonus, vehicles are free from unsightly corrosion.

Lightweight

A standard Ranger outfit can weigh up to 50 percent less than a comparable steel outfit. This translates into substantial savings in fuel consumption. A lighter outfit also means less wear on your vehicle's brakes and suspension, as well as more capacity for your payload.

Quiet

Ranger's products give a quiet ride. By building and assembling to very precise tolerances, the end product comes out tight and rattle-free. This means a more pleasant environment for the occupants of the vehicle.



Ladder Racks

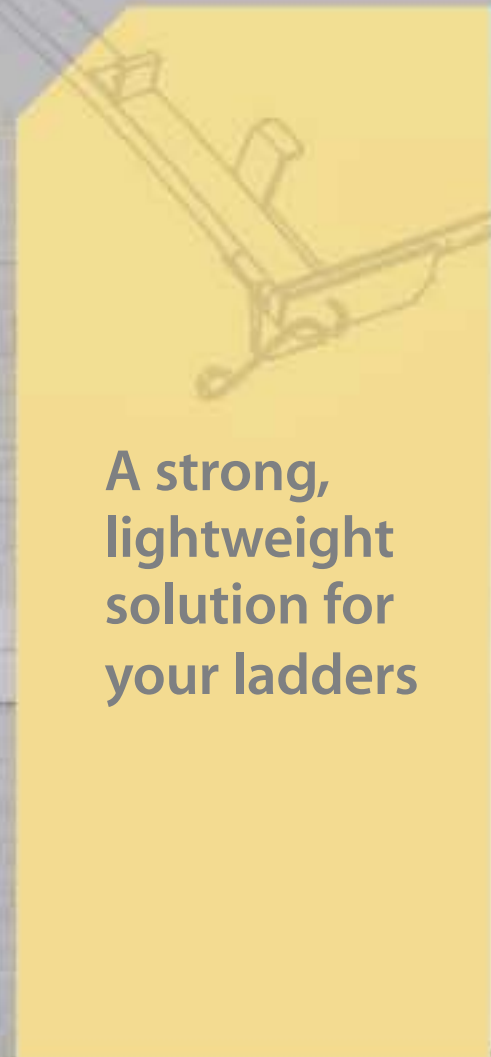

A strong,
lightweight
solution for
your ladders

Benefits

Strong

Ranger ladder racks are built to stand the test of time. Constructed of heavy-duty components and cast aluminium feet, these racks often outlast the vehicle.

Corrosion free

Made of quality 5052H32 and 6063-T5 alloy, Ranger racks will never rust. All hardware and clamps are built from stainless steel. The durable powder coat finish ensures satisfaction by maintaining a bright new sheen, year after year.

Lightweight

Amazing but true: Ranger's most popular rack, the #1025, weighs only 43 lbs.

Efficient

Reliable locking systems effectively hold extension and step ladders in place, allowing for the use of a padlock.

NOTE
Safe operation of those racks is the responsibility of the operator.
All ladders must be securely attached. Death or injury could result from ladders falling off.



Ladder Racks



Advantages

- All aluminium powder coated construction
- All stainless steel hardware and clamping mechanism
- Heavy duty cast aluminium feet for unsurpassed rigidity
- Custom designed models available for all vans
- Standard silver grey powder coat paint finish



#1025 Combination Ladder Rack

The combination ladder rack is our most popular model. It has a clamping mechanism for an extension ladder and rails to conveniently hold a stepladder. The top step of the stepladder is covered by the front hood and the back rung is attached with a nylon strap and the swing down step lock.

MODEL	APPLICATIONS	WEIGHT
1025	Full size Ford E-series	43 lbs
1025	Mini vans and most fiberglass boxes	43 lbs

Capacity 400 lbs per rack. Please specify make, model, and year of vehicle when ordering.



100% aluminium & stainless steel construction with powder coat finish

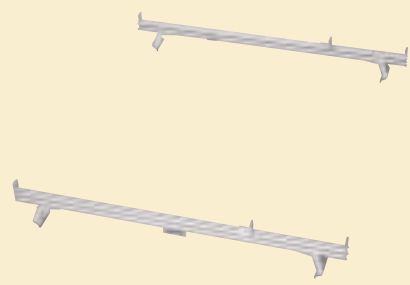

#1005 Cargo Rack

This versatile rack feature a tubular aluminium extrusion that incorporates slots for bolting accessories. This rack is ideal for carrying lumber, pipe, plywood, and ladders. Each rack includes tie-down eyes, side ladder stops, and a front wind deflector. Racks come as a pair; please specify if you want three or four bars for the same vehicle.

MODEL	APPLICATIONS	WEIGHT
1005	Full size Ford E-series	18 lbs
1005	Mini vans and fiberglass boxes	18 lbs

Capacity 240 lbs per bar. Please specify make, model, and year of vehicle when ordering. Additional bars can be used for greater payload.

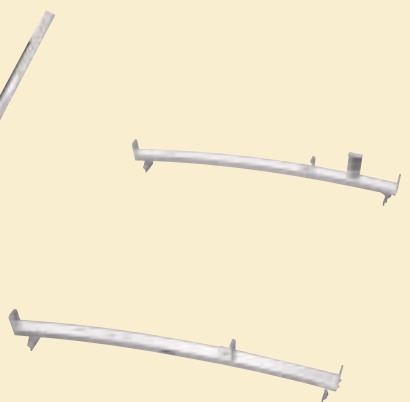

#1010 Standard Ladder Rack

This all purpose ladder rack has curved aluminium crossmembers arched to fit the roof of the van and bring the loading height as low as possible. Comes with side ladder stoppers and front hook, cast aluminium feet and stainless hardware.

MODEL	APPLICATIONS	WEIGHT
1010	Full size Ford E-series	18 lbs
1010	Mini vans and most fiberglass boxes	18 lbs

Capacity 200 lbs per bar. Please specify make, model, and year of vehicle when ordering.

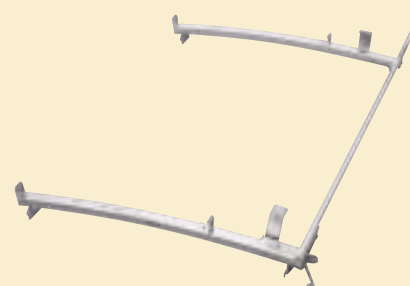

#1020 Single Side Ladder Rack

This ladder rack uses the same heavy duty crossmembers as the standard rack with the added convenience of a clamping mechanism for an extension ladder. Loading and unloading a long ladder becomes a simple one man operation, and by adding a padlock your ladder can be securely locked in place.

MODEL	APPLICATIONS	WEIGHT
1020	Full size Ford E-series	28 lbs
1020	Mini vans and most fiberglass boxes	28 lbs

Capacity 400 lbs per rack. Please specify make, model, and year of vehicle when ordering.

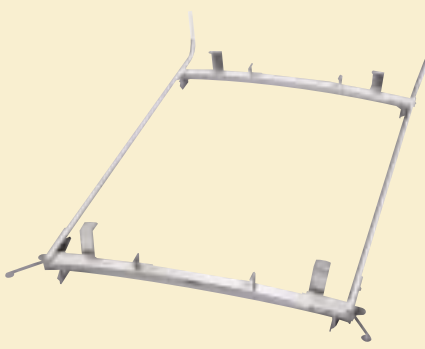

#1030 Double Side Ladder Rack

This ladder rack comes with a stainless steel clamping mechanism on both sides for safely carrying two extension ladders. Ladders can be locked by simply adding a padlock.

MODEL	APPLICATIONS	WEIGHT
1030	Full size Ford E-series	36 lbs
1030	Mini vans and most fiberglass boxes	36 lbs

Capacity 400 lbs per rack. Please specify make, model, and year of vehicle when ordering.



#6079 Transport Tube Hardware

Ranger's pipe kit turns a 6" PVC pipe into a means of transportation for long lengths that would normally clutter up the floor of your van. The cast aluminium door with a stainless hinge can be padlocked for added security. The stainless steel hoops hold it securely to your rack.

6075 - Transport Tube Door only
6079 - Transport Kit Door Kit

#1748 Roof Access Ladder

Our heavy duty access ladder for full size vans is not to be confused with lightweight recreational models. Made from heavy guage aluminium square tubing with anti-slip material on the rungs. It is fully welded and bolts to the rear door of the van for secure roof access.



#1040 Side Mount Rack

This rust-free rack is powder coated silver gray and is fabricated entirely of aluminium, stainless steel and nylon. Bolts to the side of vans or fibreglass bodies to safely carry a step ladder or an extension ladder.



Ladder Racks



Van Partitions

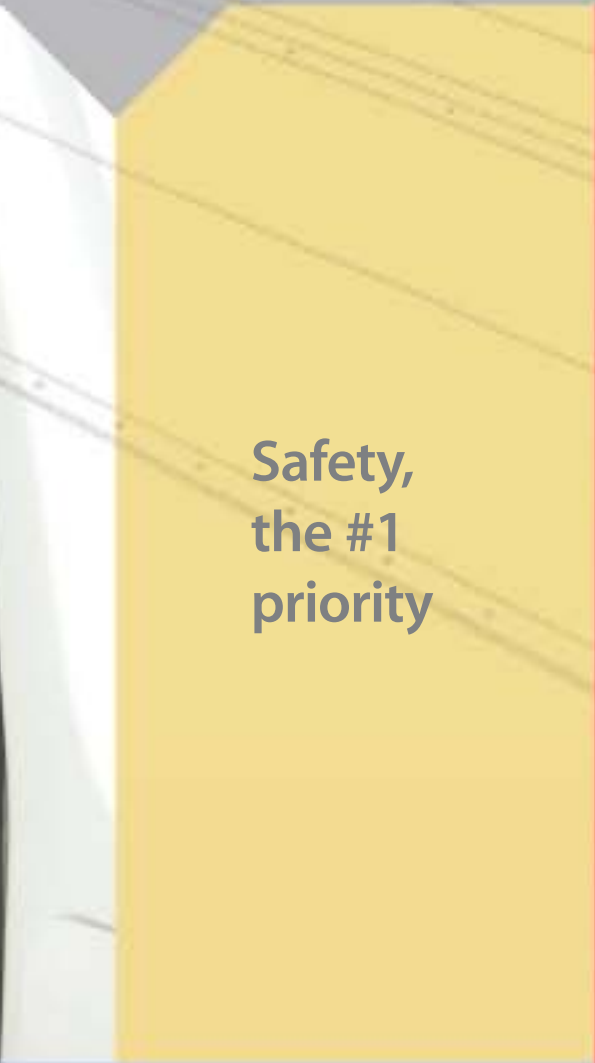

Safety,
the #1
priority



Benefits

Strong

Ranger partitions are constructed of durable .100 thick 5052H32 aluminium alloy.

Fitted

The contoured design allows for added comfort, and provides more valuable cargo space at the floor level.

Quiet

Special attention in the engineering of fit and finish guarantees a safe, rattle-free ride.

Lightweight

Ranger's most popular partition, the #3020 model, weighs only 50 lbs.

Van Partitions

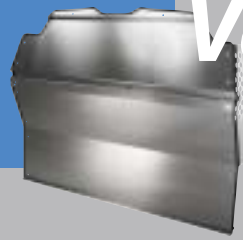

Advantages

- All Ranger partitions are built of heavy gauge aluminium alloy 5052H32
- The complete contour of the partition is finished with a heavy rubber edge trim
- Many models are available to fit a wide range of vehicles and customers needs
- Sturdy .100" thickness aluminium, brake formed for added rigidity and to provide the maximum driver protection



Model 3010



Model 3068

#3020 Van Partition with Window

Our most popular van partition comes with a tempered safety glass window. Inclined panel gives maximum space in cargo area.

MODEL	APPLICATIONS	WEIGHT
3020	Ford E-series	50 lbs
3020	Mini vans	37 lbs



Strong, secure and well-fitted

Laws in many Canadian provinces and U.S. states require that driver and passengers are protected from tools and equipment by a solid metal partition.

Loose objects must be secured. They can become dangerous projectiles in the event of severe braking or sudden stops.

Ranger Design can assume no responsibility for damage caused by unsecured objects.



#3068 Single Partitions with door

These single side partitions are an economical choice for full size vans. They can be ordered separately and are a universal fit for all full size vans. A hinged door with latch can be added for greater security.

MODEL	APPLICATIONS	WEIGHT
3060	Driver's side	15 lbs
3064	Driver's & passenger	30 lbs
3068	Complete Partition with door	46 lbs

Van Partitions

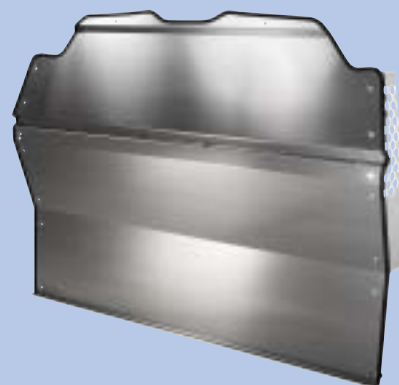

#3010 Full Van Partition

For the ultimate in security and privacy, choose Ranger's full van partition. Inclined partition gives maximum space in cargo area.

MODEL	APPLICATIONS	WEIGHT
3010	Ford E-series	45 lbs
3010	Mini Vans	32 lbs

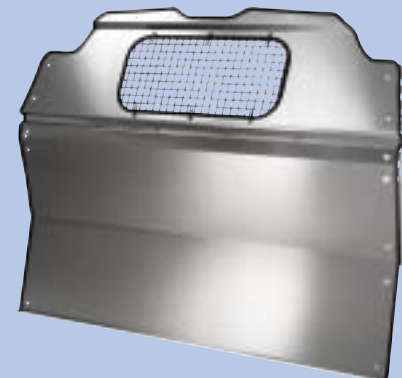

#3040 Van Partition with Grill Window

This heavy duty partition is similar to the 3020 but has a black metal grill window to allow some ventilation and circulation of air.

MODEL	APPLICATIONS	WEIGHT
3040	Ford E-series	45 lbs
3040	Mini Vans	32 lbs

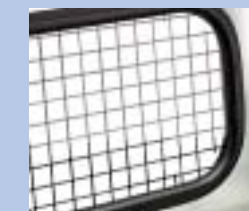

#3044 Window Grill

Ranger windows are tempered safety glass set in an extruded aluminium frame for strength and style. Window grills can be added to glass window for added security.

Shelving



Custom fit
to maximise
space



Ours...
Free floor space 42" wide!

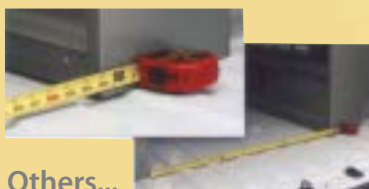

Others...
Only 35" wide!



Benefits

Strong

Ranger's exclusive shelf construction of extrusions and laminate willingly carries the load time after time.

Fitted

The contoured fit of the shelves affords 17% more floor space.

Lightweight

Extra durability doesn't necessarily mean extra weight. Ranger's popular #4048 shelf weighs a mere 44 lbs.

Quiet

Shelf dividers drop into specially engineered slots that eliminate all rattles.

Versatile

Ranger shelves are easily adjustable in order to accommodate any kind of cargo.

Shelving



Advantages

- Contoured end panels to fit the wall of the van.
- Three different shelf depths to maximize the storage capabilities.
- Front and back lip is an extruded aluminium section, perforated to receive adjustable dividers.
- Available in many lengths with over 30 standard sizes.

Ranger shelving is unique in the industry; it offers a large selection of standard sizes, and a solid attachment system. Because of the curved end panels and different depths of shelves, these units hug the wall of the van and maximize valuable floor space.

Ranger van shelving has a standard depth of 14". Clear space available on each shelf is 8" on the top shelf, 11" on the middle shelf (or shelves), and 12" on the bottom shelf. Straight back shelving for cube vans and trailers is the same depth on all shelves.

#4000 series Contoured shelving unit

This unit is contoured to better fit the side walls of a full size van. It is our most popular model and comes with three shelves (option with four shelves).



Uniquely constructed to be strong and rattle free



Model 4096 and 4048



Model 4096



#7121 Tool Case Shelf Model

This shelving is usually mounted close to the side door of a van and used for tool cases, parts boxes, etc.

Exterior sizes
21" wide x 15" deep x 36" high



#4048 Shelving unit shown with optional doors and floor angle

Shelving units are available with optional doors and floor angles.

MODEL	APPLICATIONS
7600	Floor angle 1" X 1"
7700	Each door with locking stainless steel latch



#9500 series Extra deep contoured shelving unit

This unit features extra deep shelves for increased storage. It is contoured to fit the side walls of a full size van. It comes with three shelves (option with four shelves).



#7118 Locker Shelf

Hang up overalls or protective clothing in our custom-fit locker. Comes with three hooks and a shelf on top for extra storage.

40 SERIES

Our most popular shelving is contoured to fit the wall of a full size van. Standard with 3 shelves. Option with 4 shelves.

MODEL

- 4036
- 4048
- 4060
- 4072
- 4084
- 4096

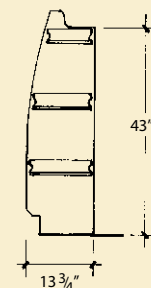

45 SERIES

Straight shelving for vans, fiberglass bodies (front) and some mini van applications. Standard with 3 shelves.

MODEL

- 4548
- 4560
- 4572
- 4596

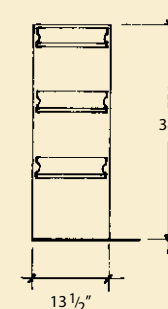

43 SERIES

Straight backed shelving for mini vans, pick up trucks, sport utility, fiberglass boxes and more. Standard with 2 shelves.

MODEL

- 4330
- 4336
- 4342
- 4348

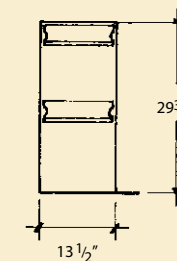

95 SERIES

This extra deep shelving is contoured to fit the wall of a full size van. Standard with 3 shelves. Option with 4 shelves.

MODEL

- 9548
- 9560
- 9572
- 9584
- 9596

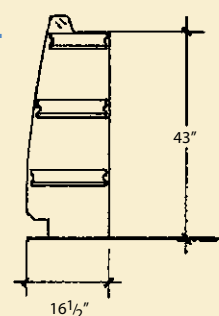

Shelving

Bin Shelving

Advantages

- All your parts in full view and easily accessible.
- Shelves sloped back to prevent spillage of stock.
- Units come complete with high quality plastic parts bins.
- Many models available for different applications.



Model 5248 on side and 5148 at front



Model 5448

#5200 series Contoured bin shelving unit

This unit is contoured to better fit the side walls of a full size van. It is our most popular bin unit. It comes with three shelves of medium bins and two shelves of small bins.



An organized approach to storage

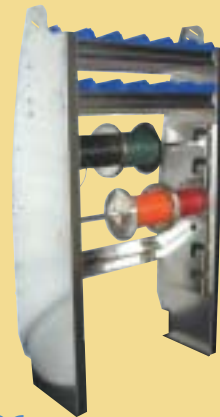

#7126 Reel Shelf

Store wire and cable reels on this versatile bin rack. Rod positions are adjustable for different reel sizes.

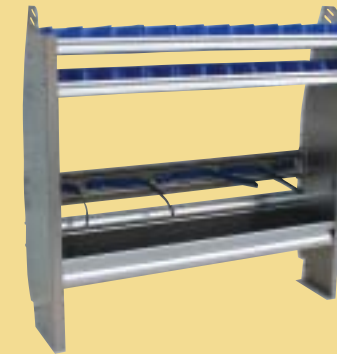

#5400 Refrigerant Bin unit

This unit is ideal for storage for tanks of refrigerant in bottles or boxes in the vertical position.



#9600 series Extra deep bin shelving unit

This unit features extra deep shelves for increased storage. It is contoured to fit the side walls of a full size van. It comes with four shelves of bins.

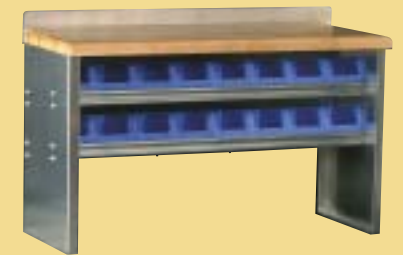

#7248 Work Bench

This heavy duty workbench with a laminated hardwood top is great for locksmiths, servicemen and others who work in their van. Comes with two rows of medium plastic bins.

Versatile storage for small parts and fasteners

#7848 Bin Shelf

Bin unit with 2 shelves of 6221 bins. Can be mounted on top of drawers or on the floor of van.

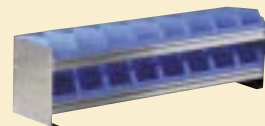

#7109 Binder Shelf

Designed for your books, binders and more, this compact unit fits nicely beside any full size shelf and is made with the same heavy duty construction.



51 SERIES

Straight backed bin unit with 3 shelves of medium bins and one shelf of small bins.

MODEL

5136
5148
5160

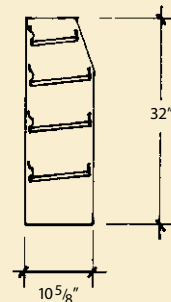

52 SERIES

Our most popular bin unit for full size van applications. 3 shelves of medium bins. 2 shelves of small bins.

MODEL

5248
5260

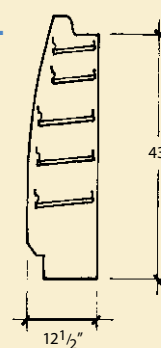

54 SERIES

Our most popular refrigerant storage shelf for full size vans. 2 shelves of small bins.

MODEL

5448
5460

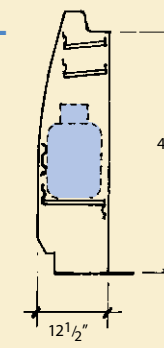

96 SERIES

This extra deep bin unit for full size van applications. 2 shelves of medium bins. 2 shelves of large bins.

MODEL

9648
9660

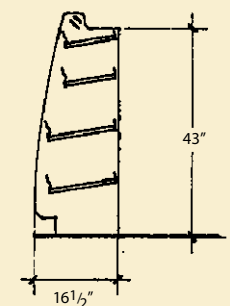

Bin Shelving

Drawer System



Easy access
to your most
used tools



Benefits

Strong

Ranger's tool drawers have an amazing capacity of 320 lbs. The parts drawers are capable of easily handling 150 lbs. of parts and fittings.

Efficient

Studies have proved that a well-organized van can save a technician at least ten minutes per day. Ten minutes x 250 days = 40 hours x \$40. The time saved translates into \$1600 per year.

Lightweight

The complete quality drawer system shown above weighs only 120 lbs.

Quiet

Ranger's drawer systems are uniquely engineered to eliminate all rattles and vibrations. Drivers are treated to a quiet, distraction-free ride.

Ergonomic

Access to all the most used tools and parts from the ground reduces back injuries caused by climbing, reaching, and twisting inside the vehicle.

Secure

Expensive or hard-to-replace tools can be safely locked in sturdy drawer compartments separate to the vehicle's security locking system.

Drawer System



Tool Drawer Advantages

- Fast, easy access to your most used tools.
- Secure, lockable storage for valuable power tools, test sets, telephones etc.
- Plenty of storage space even for tools in their carrying cases.
- Drawers roll on high quality roller bearings.
- 320 lbs capacity per drawer, heavy gauge aluminium construction.

Partslider Advantages

- Fast, easy access to your most used parts and tools.
- Drawers slide on durable low friction plastic glides, capacity 150 lbs per drawer.
- Each drawer comes complete with dividers.
- Fully assembled and adjusted.



#5020 Tool Drawer

Large capacity tool drawers are hard to find. Ranger has gone the distance to come up with one that stows so much. Made from rust free aluminium, these cases feature strong welded construction, a tray that extends on 3 ball bearing rollers, a stainless steel locking paddle latch and an attractive bright finish. These tool drawers may be installed for access by either the side or rear door of the van. For a real space-saving measure we've designed the parts drawers so that they can stack directly on top of the tool drawer.

MODEL	APPLICATIONS	WEIGHT
5020	Aluminium Tool Drawer	46 lbs

Exterior sizes	Interior sizes
48" x 13 1/2" x 16"	45" x 12 1/2" x 12 1/2"



#5020-#5010-#5012-#5048 Jumbo tool drawer with partsliders and top edge.

Ranger's tool and parts drawers can be configured in many different ways. While this is one of our most popular set-ups, Ranger's versatility allows you to find the combination that is just right for you.



#5025 Jumbo Tool Drawer

This larger capacity tool drawer is a perfect choice for larger tool kits, and for those who want more space to lock up valuable tools. The same function and features as our 5020 tool drawer.

MODEL	APPLICATIONS	WEIGHT
5025	Aluminium Jumbo Tool Drawer	52 lbs

Exterior sizes	Interior sizes
48" x 15 1/2" x 19 1/2"	45" x 14 1/2" x 16"



#5010 Partsliders

Storing parts within easy view and reach will save steps and add up to greater efficiency in the way you work. These drawers may be used alone, stacked on one another or stacked on top of tools drawer as shown. Parts tray glides smoothly on nylon guides to give easy access to your tools or parts. Dividers are included.

MODEL	APPLICATIONS	WEIGHT
5010	Drawer with bracket for mounting on top of Tool Drawer.	35 lbs
5012	Drawer with bracket for mounting on top of Parts Drawer.	35 lbs
5014	Kit to mount 5012 to floor.	

Exterior sizes	Interior sizes
48" x 12" x 6" high	46" x 11" x 4 1/4" high



#5060 Drawer Cabinet

Ranger's drawer cabinet is a high quality, heavy duty chest with drawers rolling on 150lb capacity roller drawer slides. Each drawer has adjustable aluminium dividers. This chest can be mounted in many locations in any type of vehicle and a worktop can be added to one or more units to create a workbench. A hinged bar swings over all 5 fronts and can be locked with a padlock for high security.

Exterior sizes
24" wide x 18" deep x 36" high

Interior sizes
• Two drawers 3" high X 15" X 19 1/2" (INT)
• One drawer 4" high X 15" X 19 1/2" (INT)
• One drawer 6 1/2" high X 15" X 19 1/2" (INT)
• One door 9 1/2" high

Strong, smooth roller operation you can count on

#5048, #5049, #5050 Aluminium Top edge

A necessity for storing parts on top of your drawers. Aluminium edge 4" high.

MODEL	APPLICATIONS
5048	Fits 5010
5049	Fits 5020
5050	Fits 5025

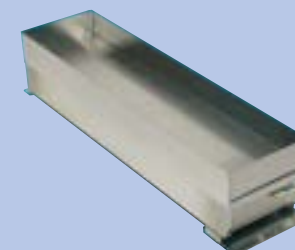

Plastic Bins

Plastic bins are available to further separate each compartment.

Small white bin CB379
3 1/4" x 2" x 2 1/2" H.

Medium blue bin EK2
3 1/2" x 3 3/4" x 2 1/2" H.

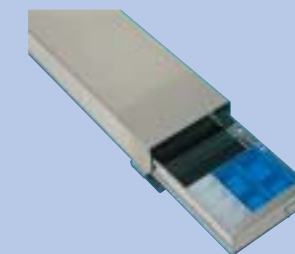

Drawer System

Organizers and Parts Storage



Advantages

Ranger's heavy duty cab boxes and parts storage systems are designed to keep your office on wheels as organized as possible. In today's mobile society this is a definite must.

#5045 Cab Organizer

This large cab box has a locking latch, pencil holder, space for hanging files and a painted cover. Ideal for all full size vans.

Exterior sizes

18" x 12" x 16" high.



#5072 Parts Keeper Floor Mount Kit

Floor mount kit with one aluminium Parts Keeper and plastic parts case. Attaches to the floor of your vehicle or to any surface.

◀ (Shown with 3 optional 5070 stacker kits)



#5070 Parts Keeper Stacker Kit

Stacker kit with one aluminium Parts Keeper and plastic parts case. Mounts on top of floor mount kit or shelf mount. Add as many stacker kits as needed to give you the storage space you required.

◀ (Shown mounted on 5074 shelfmount kit)



#5074 Parts Keeper Shelf Mount Kit

Shelf mount kit with one aluminium Parts Keeper and plastic parts case. Mounts on to any Ranger shelving unit.



#5076 Parts Keeper Under Shelf Kit

Under shelf kit with one aluminium Parts Keeper and plastic parts case. Installs underneath any Ranger shelf.



#5081 Bin Drawer Shelf With 6 Bins

Large bins pull out like drawers or remove completely as necessary. Mounts under most Ranger shelving units.



#5085 Bin Drawer Shelf With 12 Bins

Large bins pull out like drawers or remove completely as necessary.



#5040 Cab Organizer

This smaller cab box has space for letter size hanging files and a paper clip on the lid.

Exterior sizes

Size 8" x 15" x 14" high.



#5043 High Security Cab Box

This high security cab box is designed to hold lap-top computers and other valuable equipment. Comes with two locking latches.



#5046 Raised Base

This base raises the cab box to a more comfortable writing height and offers the added benefit of making the box removable.

◀ (Shown with 5045 cab box)



Standard Packages

Advantages

Available for all current full size and mini vans with some modification of part numbers.

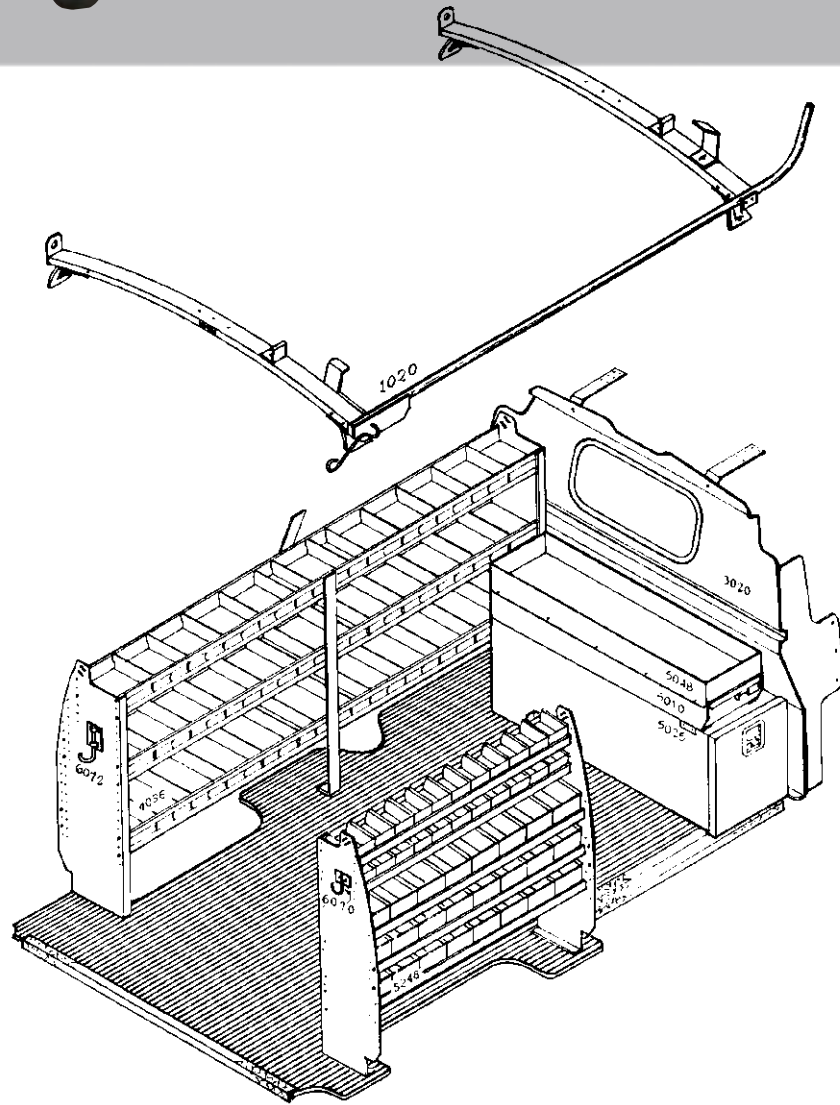

Service Package

- #1020 – Ladder rack
- #3020 – Safety partition with window
- #4096 – Shelving with 3 shelves
- #5248 – Bin unit with 5 shelves
- #5010 – Parts drawer
- #5025 – Jumbo tool drawer
- #5048 – Top edge
- #6070 – Fixed hook
- #6072 – Swivel hook



Bottle Restraint Systems

Advantages

Ranger has a wide range of options for safely transporting various tanks and bottles. Check state or provincial laws governing pressurized container transportation to be sure.



#6005 Two-Level Enclosed Bottle Holder

This bottle holder is usually mounted on the end of a shelving unit and holds two refrigerant bottles.



#6010 Two Level Bottle Holder

This adjustable bottle holder is usually mounted on the end of a shelving unit and holds refrigerant, welding kit and more.



#6015 Bottle Holder With Hinged Lid

Installs on the end of a shelving unit or on any flat surface.



#6086 Small Model #6088 Large Model Bottle Holders

A secure way to transport oxygen bottles, acetylene bottles and larger nitrogen bottles.

Bottle Restraint

Also available

Basic Contractor Package

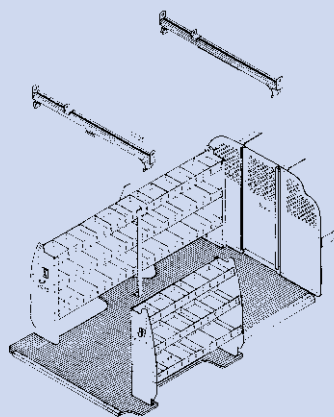

Air Conditioning / Refrigeration Package

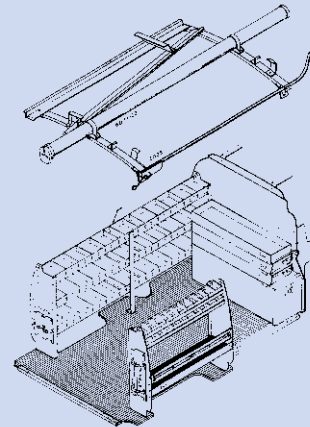

Telecom / Electrical Package

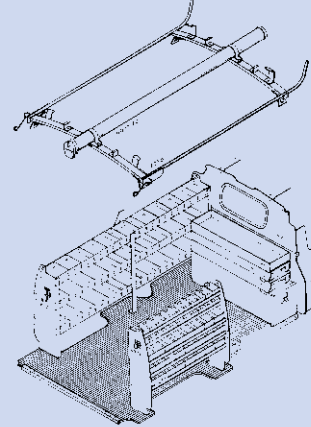

#6030 48" #6035 60" Refrigerant Bottle Rack With Straps

Many possible mounting positions. Holds 4 refrigerant bottles safely.



#6020 Refrigerant Bottle Holder

Can be mounted on top of tool drawer or any flat surface in the van. Holds up to 4 bottles of refrigerant.

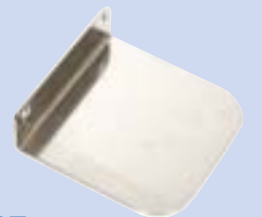

#6087 Cap For Bottle Holders

Mounts on top of small or large bottle holders (#6086 or #6088) to comply with laws in certain states and provinces.



Accessories

Advantages

Ranger offers a full range of high quality accessories to further personalise your van.

Road Safety

Bring your fleet up to current safety standards.

Have your vehicle well-equipped to protect both the driver and others on the road, with items required by law in many states and provinces



#6091 - #6094 Tie Down Ring

Secure loads with these rings.
Model #6094 Recessed



#6090 Back up Alarm

A high quality back up alarm with a die cast housing and a 106 db alarm.

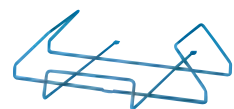

#6068 Hard hat holder

Keeps your hard hat clean, out of the way and always available.



#6062 - #6064 Fire extinguishers

High quality, refillable fire extinguishers complete with vehicle attaching brackets.

#6062 Small 2 1/2" X 16"
#6064 Large 5" X 16"



#6050 Flettner Vent

This rotary vent works much the same as an attic vent to draw air out of the vehicle as you drive. A high quality plastic product with a good seal & bearing.

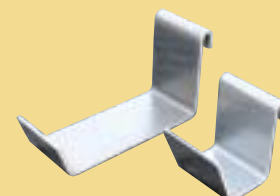

#6073 - #6074 Moveable Hooks

These heavy duty hooks can be easily moved and can be used for cords, ladders and more.

Large Model #6073
Small Model #6074



#6065 Coat Hook

Heavy duty metal hook.



#6070 Fixed hook

Large aluminium hook for cords, rope etc.
Model #6070



#6072 Swivel Hook

Extra large swivel hook for welding cables, cords, and hoses.

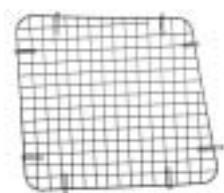

Window grills

Protect your windows from breakage and your tools from theft. Models available for most van windows, inquire for availability.



#6082 Triangle kit

Plastic case with 3 reflective triangles for roadside use. Aluminium holder with belt for secure storage.



#6080 First Aid Kit

Now a requirement in many areas, a first aid kit is always a wise addition in any service van. Ours comes with a sleek aluminium holder for ease of use.



#6211-21-31 Plastic Parts Bins

High quality plastic parts bins available separately.

Large	6231	13" x 8" x 6" H
Medium	6221	9" x 6" x 5" H
Small	6211	6 1/2" x 4" x 3" H



#6093 Grab Handle

High impact grab handle.



#6054 Hitch Step

This handy step slides into a 2" x 2" hitch and combines the strength of a steel shaft with the security of an aluminium grip step.



#6085 Folding Step

This zinc plated step gives you that needed height when something is just out of reach, and folds up when you are done with it.



#6052 Slide Out Holder

This steel slide-out vise holder can be mounted at the back or side of a van, and locks solidly in the in or out position.

Lighting

Make sure your vehicle is highly visible on the outside and well lit on the inside.

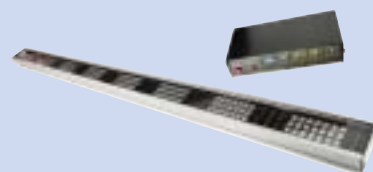

#6081 Warning Arrow

Star model 7730 Arrow stick has L.E.D. lights for long life and very high visibility. Only 1 amp draw.



#6083 Amber strobe

Star model 200 A can be wired to flash single, dual, or quad. A very high quality strobe light.

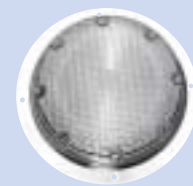

#6092 Dome Light

This 7" diameter light with chrome ring far exceeds the standard lights found in vans. Standard 1156 bulb.



#6056 Deluxe Paper Holder

for log books and more. 9 1/2" x 2" x 6" high.



#6057 Aluminium Holder

Fits 3 aerosol cans or other parts. Can be mounted on partition or shelf end. 10" wide x 3" deep x 3" high.



#6069 - #6067 Paper Holder

With 12" clear in every pocket our holders will fit folders, catalogues, papers and more. Available with 2 or 5 slots. 6067 2 slots 14" x 12" ext. 6069 5 slots 14" x 24" ext.

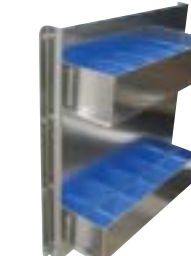

#6066 Two-Pocket Door Panel

Mounts to the door on most vans. With 2 deep pockets that prevent items from falling out but still keep them visible.

*Please request
Ranger catalogues
for these other
applications*



GM



Chrysler



Pick-up and Truck



Made in Canada by:



Ranger Design Inc.

19160 Cruickshank, Baie-D'Urfé,
Quebec, Canada H9X 3P1

Tel.: 514-457-8181
Toll free: 1-800-565-5321
Fax: 514-457-8180

Your Ranger Distributor:

Ce catalogue est disponible en français.
Printed in Canada © January 2007